

Kanalgenerator Typ G 3490 0000



- Erzeugt das Dupline® Trägersignal für 8, 16, 24, 32, 40, 48, 56, 64, 96 oder 128 Kanäle
- Anzahl Kanäle wählbar durch Drehschalter
- Anzahl Zyklen (1 oder 2) mit Codiermodul wählbar
- Quarzgesteuerter Oszillator
- Kabelkompensierung
- Steckbare und auf DIN-Schiene aufrastbare Ausführung gemäss (EN 50022)
- LED-Funktionsanzeigen
- Betriebsspannung AC oder DC

Produktbeschreibung

Standardkanalgenerator für alle Dupline® Systeme. Anzahl der Kanäle mit Drehschalter wählbar.

Bestellschlüssel

G 34900000 230

Typ: Dupline®
Kanalgenerator
Betriebsspannung

Typenwahl

Betriebsspannung

24 VAC
115 VAC
230 VAC

15 bis 30 VDC

Bestellnummer

G 3490 0000 024
G 3490 0000 115
G 3490 0000 230

G 3490 0000 824

Daten Signaleingang/-ausgang

Ansteuerung

Funktion
Leerlaufspannung
Kontaktschaltleistung
Kontaktwiderstand
Leitungslänge
AC Bemessungsspannung
Eingang gegen Dupline®

1 Kontakt
2 Zyklen
12 VDC
1.25 mA
≤ 100 Ω
≤ 3 m
Keine

Ausgänge

Anzahl Ausgänge
Ausgangsspannung
Strom
Kurzschlusschutz
Ausgangsimpedanz

Dupline® Trägersignal
1
8.2 VDC
≤ 70 mA
≤ 600 s
≤ 25 Ω

Outputs (cont.)

Zykluszeit

1 Zyklus (± 1%)

Drehschalter
Position:

Drehschalter Position:	Anzahl Kanäle:	Zykluszeit
A	8	15.63 ms
B	16	23.44 ms
C	24	31.25 ms
D	32	39.06 ms
E	40	46.87 ms
F	48	54.68 ms
G	56	62.49 ms
H	64	70.31 ms
L	96	101.54 ms
P	128	132.80 ms

Abstand zum Sender

100% (siehe Leitungslänge)

* Bei 2 Zyklen wird die Übertragungszeit 2 mal größer.

Daten Betriebsspannung

Betriebsspannung AC-Typen	Überspann.kat. III (IEC 60664)
Nenn-Betriebsspannung	
an Klemmen: 21 & 22	230 230 VAC ± 10% (IEC 60038)
	115 115 VAC ± 10% (IEC 60038)
	024 24 VAC ± 10%
Netzfrequenz	45 to 65 Hz
Leistungsverkef	4 W
Spannungsunterbrechung	≤ 40 ms
Nenn-Leistungsaufnahme	Typisch 2,5 VA
Bemessungsstoßspannung	
	230 4 kV
	115 2.5 kV
	024 800 V
AC Bemessungsspannung	
Netz gegen Dupline®	≥ 4 kVAC (rms)
Netz gegen Eingänge	≥ 4 kVAC (rms)
Betriebsspannung DC-Typen	Überspann.kat. III (IEC 60664)
Nenn-Betriebsspannung	
an Klemmen: 21 & 22	824 15 bis 30 VDC (einschl. Restwelligkeit)
Leistungsverkef	3 W
Restwelligkeit	≤ 3 V
Verpolungsschutz	Ja
Nenn-Stromaufnahme	≤ 90 mA
Einschaltstrom	≤ 1 A
Bemessungsstoßspannung	800 V
AC Bemessungsspannung	
Versorgung gegen Dupline®	Keine
Versorgung gegen Eingang	≥ 200 VAC (rms)

Allgemeine technische Daten

Einschaltverzögerung	≤ 3 s
Anzeige für	
Betriebsspannung EIN	LED, grün
Dupline® Trägersignal *	LED, gelb
Umgebungsbedingungen	
Schutzart	IP 20
Verschmutzungsgrad	3 (IEC 60664)
Betriebstemperatur	-20° bis +50°C (-4° bis +122°F)
Lagertemperatur	-50° bis +85°C (-58° bis +185°F)
Luftfeuchtigkeit (nicht kondens.)	20 bis 80%
Mechanische Beanspruchung	
Stoßfestigkeit	15 G (11 ms)
Rüttelfestigkeit	2 G (6 bis 55 Hz)
Abmessungen	
Material	
(siehe "Technische Informationen")	H4-Gehäuse
Gewicht	250 g
Zertifizierung	IEC/EN 61508-SIL3 EN954 cat 4 TÜV Rheinland Group c(U)us

Arbeitsweise

Der Kanalgenerator erzeugt die Taktzyklen und synchronisiert die Übertragungssignale für ein System von Dupline® Modulen. Gleichzeitig versorgt er Dupline® Sender ohne externe Betriebsspannung. Bei Codiermodulen für 1 oder 2 Zyklen muss der Signalzustand eines Senders für 1 oder 2 fortlaufende Zyklen identisch sein, ehe der Kanalgenerator für den betreffenden Kanal das Puls-Pausenverhältnis ändert. Durch diese Ände-

rung des Puls-Pausenverhältnisses ändert sich der Zustand der Empfänger.

Anmerkung:

- Wenn analoge Module oder Zähler eingesetzt werden, dürfen keine Codiermodule für 2 Zyklen gewählt werden.

- Bei 2 Zyklen wird die Übertragungszeit eines Dupline® Systems um bis zu 33% der unter "Übertragungszeit" angeführten Werte verlängert.

In Dupline® Systemen mit digitalen Sendern und Empfängern werden 2 Zyklen nur bei einer Verkabelung in Umgebungen mit starken elektrischen Störungen empfohlen. 2 Zyklen gewähren eine absolut korrekte Übertragung, reduzieren aber auch die Reaktionszeit des Systemes.

Auf die Dupline® Leitung gekoppelte HF-Signale können durch Verbindung der Klemmen 4 und 1 zum Teil unterdrückt werden. Bei

induktiven Leitungen kann ein externer Kondensator von <1 µF zwischen Klemme 1 & 2 eingesetzt werden. In den meisten Fällen ist die Leitung aber kapazitiv und erfordert keinen Kondensator.

Anmerkung:

Es wird empfohlen, den Kanalgenerator in die Mitte des Dupline® Systems einzusetzen.

Signaldiagramm

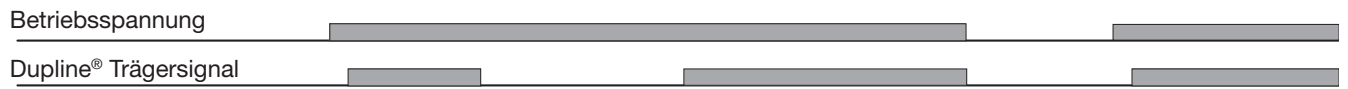

Schaltbild

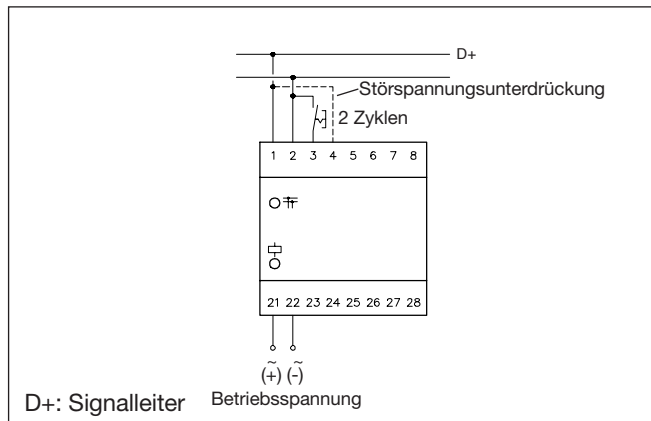

Abmessungen (mm)

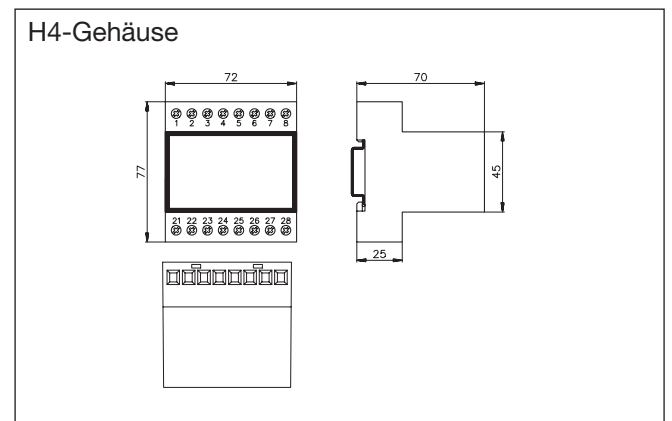

Zubehör

DIN-Schiene

FMD 411

Weitere Einzelheiten finden Sie im Abschnitt "Zubehör" des Dupline® Katalogs.

Dupline®/Optical Fibre Converters Types G 3492 0000 and G 3493 0000

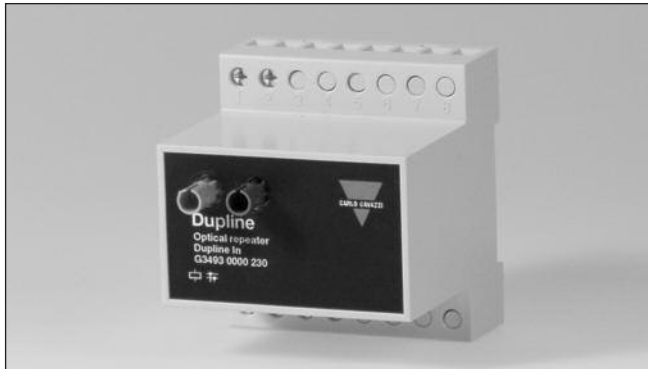

- Converts Dupline® for transmission on optical fibre
- Runs on optical multimode fibre pairs (50/125, 62.5/125)
- ST type connector
- Up to 5 km optical transmission distance with 62.5/125 fibre
- DIN-rail mounting
- LED-indications for supply and fibre connection
- AC power supply

Product Description

The G34930000 converts the Dupline® signal for transmission on optical multimode fibre pairs (50/125, 62.5/125). The G34930000 always operates together with a G34920000, which converts

the signal back from optical to electrical representation via a built-in channel generator output stage. Up to 5 km optical transmission distance can be achieved.

Ordering Key

G 3493 0000 230

Type: Dupline® _____
Function _____
Power supply _____

Type Selection

Supply	Ordering no. Optical-to-Electrical Converter	Ordering no. Electrical-to-Optical Converter
115/230 VAC 24 VAC	G 3492 0000 230 G 3492 0000 024	G 3493 0000 230 G 3493 0000 024

Supply Specifications

Power supply	AC-Types	Overvoltage cat. III (IEC 60664)
Rated operational voltage through term. 21 & 24 jumper term. 22 & 23	230	230 VAC ± 15% (IEC 60038)
*) through term. 21 & 22 jumper term. 24 & 22 jumper term. 21 & 23	115	115 VAC ± 15% (IEC 60038)
through term. 21 & 22	024	24 VAC ± 15% (IEC 60038)
Frequency		45 to 65 Hz
Rated operational power		Typ. 3 W
Power dissipation		≤ 4 W
Rated impulse withstand voltage	230 V 115 V 024 V	4 kV 2.5 kV 800 V
Dielectric voltage Supply - Dupline®		≥ 4 kVAC (rms)

Input/Output Specifications

Optical Interface	
Optical fibre type	Multimode Glass fibre
Dimensions	50/125 or 62.5/125
Connectors	ST plugs
Optical power budget @ 25°C	15dB (62.5/125 µm fibre) 10.5dB (50/125 µm fibre)
Transmission distance	Up to 5 km (62.5/125 fibre)
Output (G 3492 0000 only)	Secondary Dupline®
Number of outputs	1
Output voltage	8.2 VDC
Current	≤ 40 mA
Short-circuit protection	≤ 60 s
Sequence time	Follows primary Dupline®
Dupline® transmission delay from	
- primary to secondary	1 mSec
- secondary to primary	max 1 Dupline® scan 136 mSec

*)When use of 115 VAC, make sure to parallel the terminals as shown.

General Specifications

Power ON delay	< 1.5 s	Humidity (non-condensing)	20 to 80% RH
Indication for		Mechanical resistance	
Supply ON	LED, green	Shock	15 G (11 ms)
Dupline® carrier	LED, yellow	Vibration	2 G (6 to 55 Hz)
Optical communication	LED, yellow	Dimensions	
Environment		Material	
Degree of protection	IP 20	(see "Technical Information")	H4-housing
Pollution degree	3 (IEC 60664)	Weight	250 g
Operating temperature	0° to +50°C (+32° to +122°F)		
Storage temperature	-20° to +85°C (-4° to +185°F)		

Wiring Diagrams

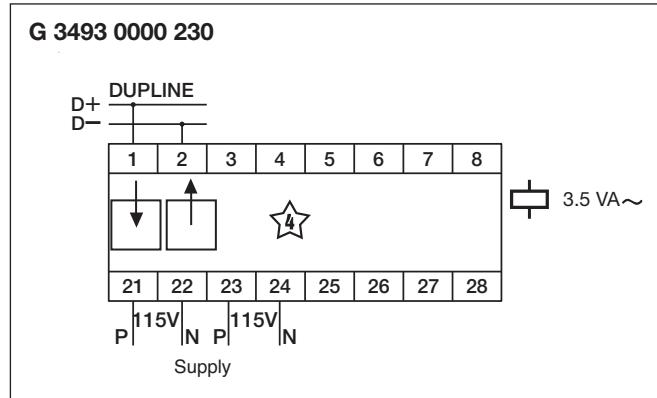
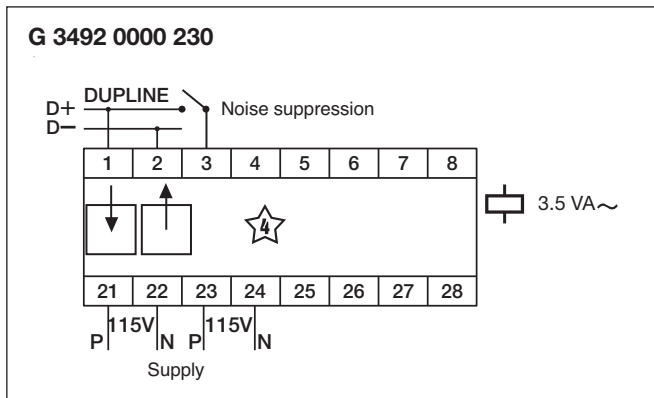
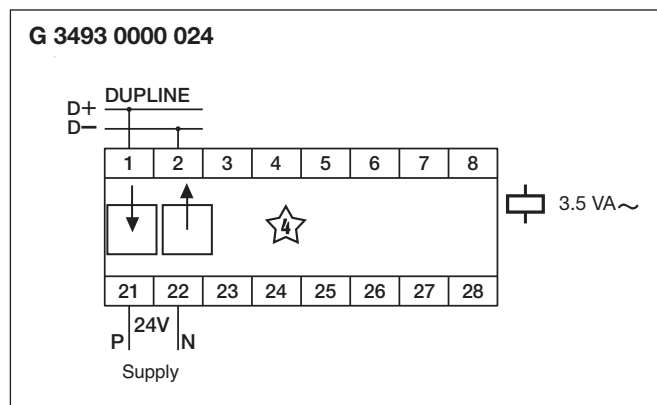
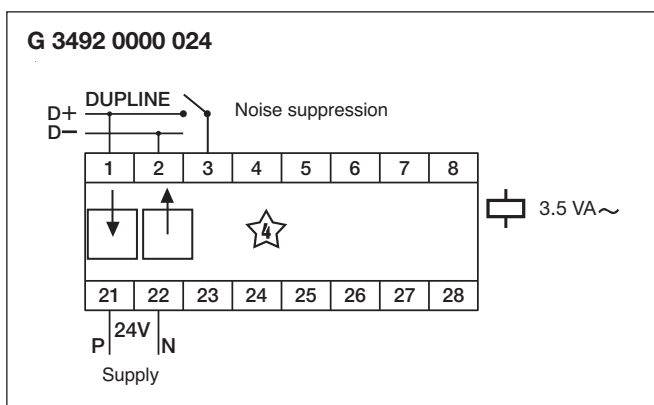

Mode of Operation

The Dupline® Optical Converters enable the use of glass fibre as transmission media on one or more sections of a Dupline® Fieldbus network. The possibility to freely combine electrical and optical media makes it easier to adapt the Dupline® Field-

bus to the system requirements. Optical Fibres can be useful when Dupline® signals have to be transmitted outdoor in geographical areas with frequent thunderstorms, or in case of sections with heavy noise induction.

The G 3493 0000 converts the Dupline® signal from electrical to optical level, while the G 3492 0000 with built-in channel generator converts the carrier signal back from optical to electrical level (secondary Dupline®). Up to 5 km distance can be achieved

on the glass fibre, which can have the dimensions 50/125 or 62.5/125. Two optical fibres are required for connecting the two Optical Converter Units.

Application

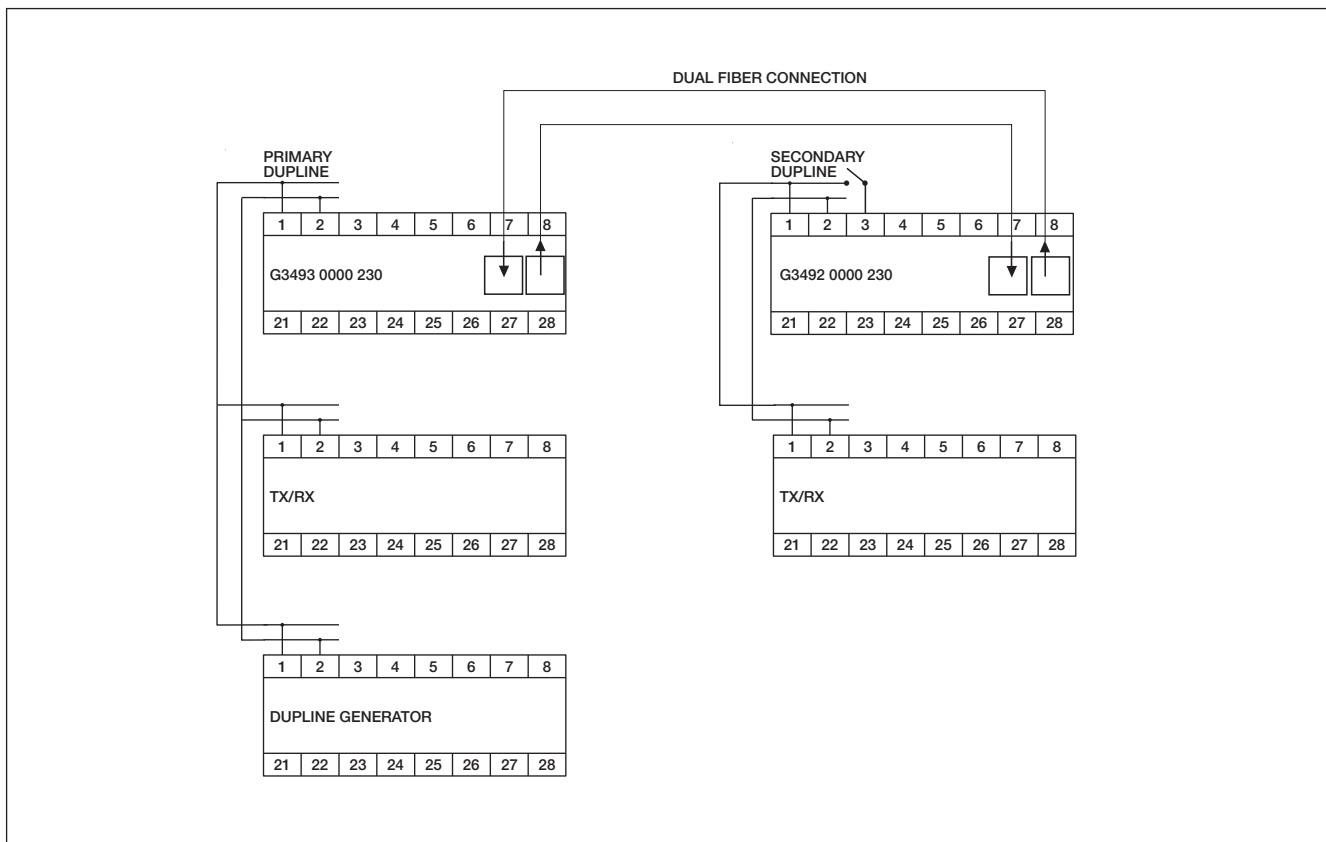

Dimensions (mm)

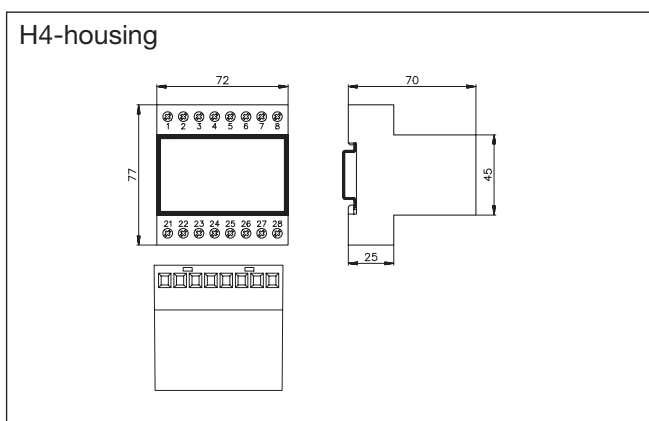

Universal Analog Output Module for DIN-Signals Type G 3439 6470

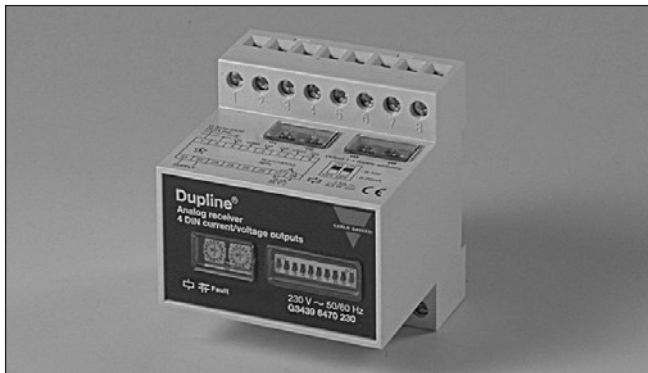

- 4 analog outputs
- Outputs individually configurable for 0-20 mA, 4-20 mA or 0-10 VDC
- Selectable resolution: 1/1999 or 1/255 of full scale
- Selectable dataformat : 8-bit, AnaLink or 3 1/2 digit BCD
- EMC immunity according to EN50082-2 (industrial environment)
- DIN-rail mounting (EN 50022)
- Address-selection through rotary switches
- LED-indication for supply and Dupline® carrier
- LED-indication for invalid switch setting and faulty received data
- Watchdog output for faulty received data
- H4 housing

Product Description

Dupline® 4 output universal analog output module with internal supply. The module receives signals on a digital format from Dupline® and converts them to analog outputs. The output type can be selected as 0-20 mA, 4-20 mA or 0-10 VDC for each output individually making a mix of analog output types on

the same module possible. The transmission format on Dupline® can be selected to fit the output module into existing installations, or simply to use the most suitable combination of resolution, signalling capacity and speed. The formats are: 8-bit binary, AnaLink and 3 1/2 digit BCD (with or without multiplexing).

Ordering Key

G 3439 6470 024

Type: Dupline® _____
 H4-housing _____
 Receiver _____
 No. of channels _____
 Output type _____
 Power supply _____

Type Selection

Supply

24 VAC
 115 VAC
 230 VAC
 10-30 VDC

Ordering no.

G 3439 6470 024
 G 3439 6470 115
 G 3439 6470 230
 G 3439 6470 800

Output Specifications

	Outputs set to voltage	Outputs set to current
Signal		
Signal output	DIN-voltage output	DIN-current output
Signal range	0-10 VDC	0-20 mA / 4-20 mA
Output load	≥ 100 kΩ	0-450 Ω
Short circuit protection	Yes	Yes
Watchdog output	≤ 30 V	≤ 50 mA
Resolution		
A/D	11 bits or 8 bits	11 bits or 8 bits
Transmission	1/1999 or 1/255	1/1999 or 1/255
Output settling time	≤ 0.5 sec.	≤ 0.5 sec
Inaccuracy (11-bit) (ref. temp. 25°C)	< 0.4% of full-scale < 0.2% of reading < 1 count	< 0.4% of full-scale < 0.2% of reading < 1 count
Temperature influence (ref. temp. 25°C)	< ±15 ppm/K of full-scale < ±150 ppm/K of reading	< ±15 ppm/K of full-scale < ±150 ppm/K of reading
Recommended cable length	< 25 m	< 25 m
Dielectric voltage		
Output - Dupline®	250 VAC (rms)	250 VAC (rms)
Output - Watchdog output	2 kVAC (rms)	2 kVAC (rms)

Supply Specifications

Power supply AC-types	Overvoltage cat. III (IEC 60664)
Operational voltage through term. 21 & 22	230 230 VAC, -10/+15 % (IEC 60038)
	115 115 VAC, -10/+15 % (IEC 60038)
	024 24 VAC, -10/+15 %
Frequency	45 to 65 Hz
Power consumption	typ. 7 VA
Power dissipation	≤ 8 W
Rated impulse withstand voltage	230 4 kV
	115 2.5 kV
	024 800 V
Dielectric Voltage	
Supply - Dupline®	4 kVAC (rms)
Supply - Signal output	4 kVAC (rms)
Supply - Watchdog output	4 kVAC (rms)
Power supply DC-types	
Operational voltage through term. 21 & 22	800 10,5 V - 30 VDC (Ripple incl.)
Ripple	< 3 V
Reverse polarity protection	Yes
Power consumption	< 4 W
Power dissipation	< 6 W
Rated impulse withstand voltage	800 V
Dielectric Voltage	
Supply - Dupline®	500 VAC (rms)
Supply - Signal output	250 VAC (rms)
Supply - Watchdog output	2 kVAC (rms)

General Specifications

Power ON delay	≤ 2 s
Indication for	
Supply ON	LED, green
Dupline® carrier	LED, yellow
Dupline® format error	LED, red
Illegal switch setting	LED, red - flashing
Environment	
Degree of protection	IP 20
Pollution degree	3 (IEC 60664)
Operating temperature	0° to +50°C (+32° to +122°F)
Storage temperature	-20° to +85°C (-4° to +185°F)
Humidity (non-condensing)	20 to 80%
Mechanical resistance	
Shock	15 G (11 ms)
Vibration	2 G (6 to 55 Hz)
Dimensions	
Material (see Technical information)	H4-Housing
Weight	300 g
CE-marking	Yes

Switch Settings

Shunt-switches on system top

Current shunts on output 1-4:
 ON/ON = 0-10 V / (2-10 V)
 OFF/OFF = 0-20 mA / 4-20 mA

Rotary switches in the front

Mode	<input type="checkbox"/> A-P	<input type="checkbox"/> 0-F
3 1/2 digit:	Channel group-pair Ex. setting: C or D = C-D	Mux. address for output 1, rest of the outputs (if enabled) on the following addresses
8-bit:	Channel group	Same as 3 1/2 digit. Ex. setting 5 (with 2 outputs enabled) = Output 1 on mux address 5 Output 2 on mux address 6
Analink:	Channel group	Channel no. for output 1, rest of the outputs (if enabled) on the following channels. Setting of 0+9-F is not valid.

Function switches in the front

Offset on output 1-4
 ON = 4-20 mA / (2-10 V)
 OFF = 0-20 mA / 0-10 V

No. of enabled outputs
 OFF ON : 1
 ON OFF : 2
 ON ON : 3
 OFF OFF : 4

Mode (Format)
 OFF OFF : Analink
 OFF ON : 8-bit binary
 ON OFF : 3 1/2 digit BCD
 ON ON : Reserved for future use

Multiplex ON/OFF
 (Only used in 3 1/2 digit BCD and 8-bit binary mode)
 ON = Data is multiplexed
 OFF = Data to output 1 is received on the group (or grouppair) rotarysw. A-P is set to,
 data from input 2, 3, 4 (if enabled) on the following groups (or grouppairs)

Maintain ON/OFF
 ON = Keep output in case of Dupline® (or format) error
 OFF = Zero output in case of Dupline® (or format) error

Wiring Diagram

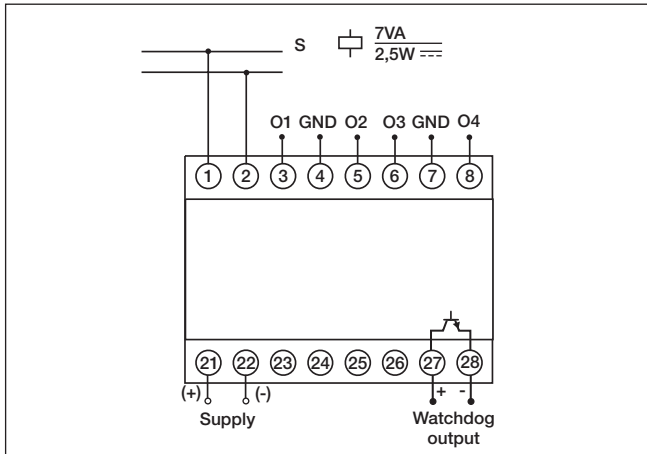

Dimensions (mm)

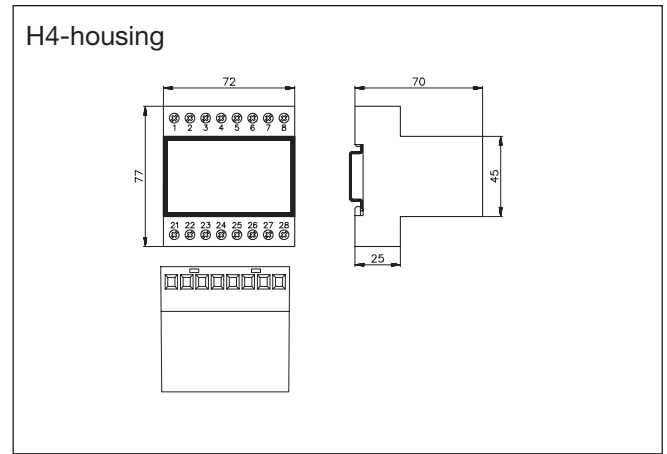

Mode of Operation

The G34396470 is a universal analog module with 4 outputs. The outputs can be configured individually for 0-20 mA, 4-20 mA or 0-10 VDC signals, making a mix of analog output types on the same module possible. The transmission format is selectable and supports all Dupline analog protocols: 8-bit, Analink and 3 1/2 digit BCD. The module can be used in normal or multiplexed mode. Address coding is done by means of rotary switches and the output and protocol selection is done by means of DIP-switches, so the GAP 1605 Programmer is not required.

With reference to the diagram on the previous page, the setting of the module should be performed in the following way:

Select current or voltage signal for each output by means of the 4 double-DIP-switches on the top of the module. If 4-20 mA is desired for an output select off-set ON for the corresponding switch on the front of the module. The module only outputs signals according to the selected

number of enabled outputs on switches 5 and 6.

Address allocation for the Analink protocol:

If all four outputs are enabled, the module will use four Dupline channels in consecutive order, starting from the address set on the two rotary switches on the front of the unit.

Example: Setting of "D7" means that output 1 receives on Dupline channel D7, output 2 receives on D8, output 3 receives on E1 and output 4 receives on E2.

Address allocation for the 8-bit binary protocol:

If all four outputs are enabled and non-multiplexed mode is selected (switch 9), the module will use four Dupline channel groups (32 channels) in consecutive order, starting from the group set on the first rotary switch (A-P). The second rotary switch (0-F) is not used in this mode.

Example: Setting of "F" on the first rotary switch means that output 1 receives on Dupline group F, output 2 receives on G, output 3 receives on H and output 4 receives on I.

If multiplexed mode is selected the module will use one Dupline channel group (8 channels). The first rotary switch (A-P) is used to set the group and the second rotary switch (0-F) to set the multiplex address to be used by the first output, no. 1.

Example: Setting of "F" on the first rotary switch and "0" on the second, means that output 1 receives on Dupline group F mux. adr. 0, output 2 receives on F mux. adr. 1, output 3 receives on F mux. adr. 2 and output 4 receives on F mux. adr. 3.

Address allocation for the 3 1/2 digit BCD protocol:

If all four outputs are enabled and non-multiplexed mode is selected (switch 9) the module will use four Dupline channel group-pairs (64 channels) in consecutive order. The first rotary switch (A-P) is used to set the start group pair. The second rotary switch (0-F) has no function in this mode.

Example: Setting of "C" or "D" on the first rotary switch means that output 1 receives on Dupline group-pair C-D, output 2 receives on E-F,

output 3 receives on G-H and output 4 receives on I-J.

If multiplexed mode is selected the module will use one Dupline channel group-pair (16 channels). The first rotary switch (A-P) is used to set the group-pair and the second rotary switch (0-F) to set the multiplex address to be used by the first output, no. 1.

Example: Setting of "C" or "D" on the first rotary switch and "8" on the second, means that output 1 receives on Dupline group-pair C-D mux. adr. 8, output 2 receives on C-D mux. adr. 9, output 3 receives on C-D mux. adr. A and output 4 receives on C-D mux. adr. B.

Note

The selected protocol is valid for all enabled outputs. The module can not receive different protocols at the same time.

Analog receivers must not be used in systems where channel generators with 2 or 3 sequences are installed.

Accessories

DIN Rail

FMD 411

For further information refer to "Accessories".

Receiver for Digital Signals

Types G 3430 5511, G 3430 5521



- 8-channel receiver
- Optoisolated NPN (sink) or PNP (source) transistor outputs
- Load: 8 x 0.7 A/60 VDC
- Reverse-polarity protection
- H4-housing
- For mounting on DIN-rail (EN 50022)
- LED-indications for supply and Dupline® carrier
- AC or DC power supply
- Channel coding by GAP 1605

Product Description

Dupline® receiver. transistor outputs for control of loads up to 60 VDC/0.7 A.
Open collector NPN or PNP

Ordering Key

G 3430 5521 024

Type: Dupline® _____
H4-housing _____
Receiver _____
No. of channels _____
Output type _____
Power supply _____

Type Selection

Supply	Ordering no. 8 channels 0.7 A/60 VDC NPN transistor	Ordering no. 8 channels 0.7 A/60 VDC PNP transistor
24 VAC	G 3430 5511 024	G 3430 5521 024
115 VAC	G 3430 5511 115	G 3430 5521 115
230 VAC	G 3430 5511 230	G 3430 5521 230
10 to 30 VDC	G 3430 5511 800	G 3430 5521 800

Output Specifications

	G 3430 5511 ... (8 channels)	G 3430 5521 ... (8 channels)
Outputs	8 NPN transistors	8 PNP transistors
Isolated in groups of	1 x 8	1 x 8
Output voltage range V_{BB}	6 to 60 VDC	6 to 60 VDC
Reverse-polarity protection	Yes	Yes
Current per output (25°C)	≤ 0.7 A	≤ 0.7 A
Total load capability (25°C)	51%	51%
Short-circuit protection	None	None
Built-in protective diodes	None	None
Off-state leakage current	≤ 100 µA	≤ 100 µA
Output voltage drop	≤ 1.5 VDC	≤ 1.5 VDC
Dielectric voltage	≥ 4 kVAC (rms)	≥ 4 kVAC (rms)
Outputs - Dupline®		

Supply Specifications

Power supply AC types		Overvoltage cat. III (IEC 60664)	Power supply DC types		Overvoltage cat. III (IEC 60664)
Rated operational voltage terminals 21 & 22	230 115 024	230 VAC ± 15% (IEC 60038) 115 VAC ± 15% (IEC 60038) 24 VAC ± 15%	Rated operational voltage terminals 21 & 22	800	10 to 30 VDC (ripple included) ≤ 3 V
Frequency		45 to 65 Hz	Ripple		Yes
Voltage interruption		≤ 40 ms	Reverse-polarity protection		≤ 150 mA
Rated operational power		Typ. 3.5 VA	Rated operational current		≤ 5.5 W
Power dissipation		≤ 8 W	Power dissipation		≤ 1 A
Rated impulse withstand voltage	230 115 024	4 kV 2.5 kV 800 V	Inrush current		800 V
Dielectric voltage Supply - Dupline®		≥ 4 kVAC (rms)	Rated impulse withstand voltage		≥ 200 VAC (rms)
Supply - Outputs		≥ 4 kVAC (rms)	Dielectric voltage Supply - Dupline®		≥ 4 kVAC (rms)
			Supply - Outputs		

General Specifications

Power ON delay	Typ. 2 s
Power OFF delay	≤ 1 s
Output OFF delay upon loss of Dupline® carrier	≤ 20 ms
Indication for Supply ON Dupline® carrier	LED, green LED, yellow
Environment	
Degree of protection	IP 20
Pollution degree	3 (IEC 60664)
Operating temperature	-20° to +50°C (-4° to +122°F)
Storage temperature	-50° to +85°C (-58° to +185°F)
Humidity (non-condensing)	20 to 80%
Mechanical resistance	
Shock	15 G (11 ms)
Vibration	2 G (6 to 55 Hz)
Dimensions	
Material (see Technical information)	4H-housing
Weight	
AC types	250 g
DC types	200 g

Mode of Operation

G 3430 55.1 ... 8-channel receivers with 8 open collector NPN or PNP outputs

Each output may be coded individually by means of the code programmer GAP 1605. See separate data sheet.

The outputs are normally off. When a transmitter coded to the selected channel is activated, the output turns on and remains on until the respective channel becomes deactivated (interruption or short-circuiting of Dupline® carrier).

Derating Curve

The curve shows the current allowed per output at different temperatures. The dotted line indicates the total load capability per receiver at different temperatures.

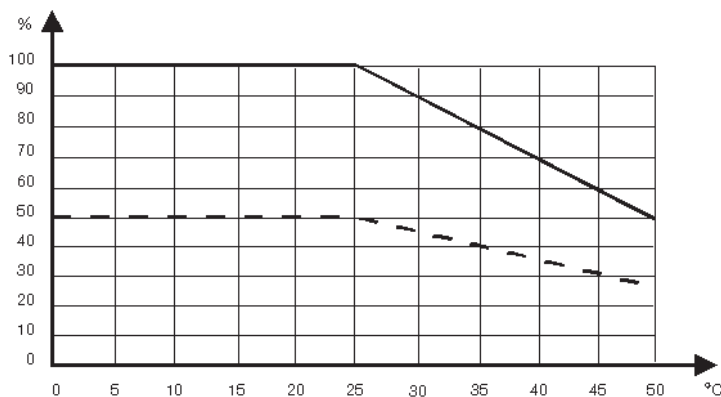

Operation Diagram

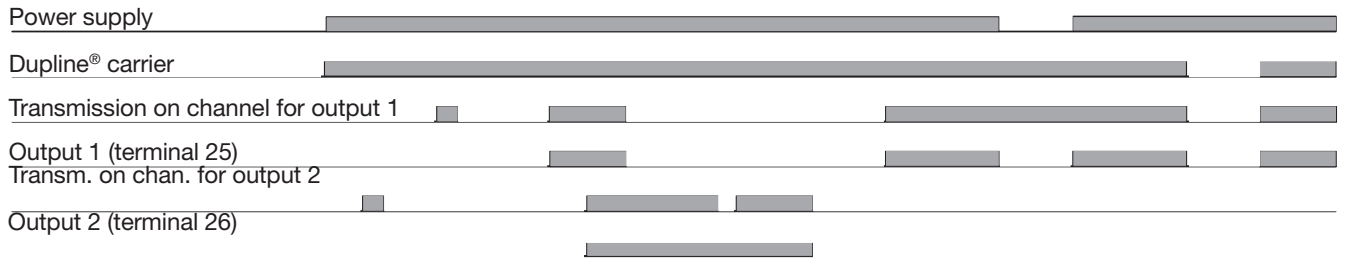

Wiring Diagrams

G 3430 5511 ... 8 channels
Open collector NPN transistor output

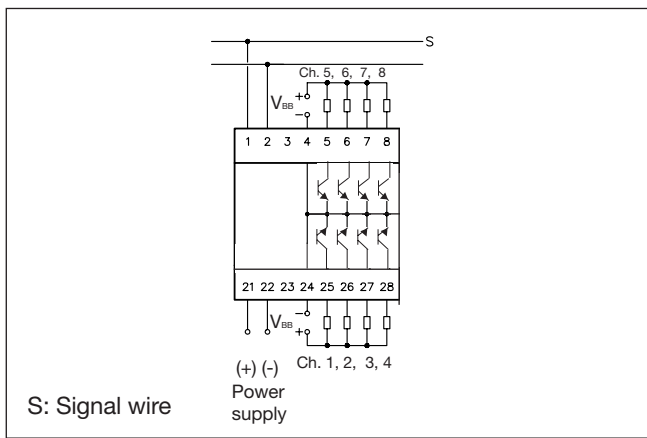

G 3430 5521 ... 8 channels
Open collector PNP transistor output

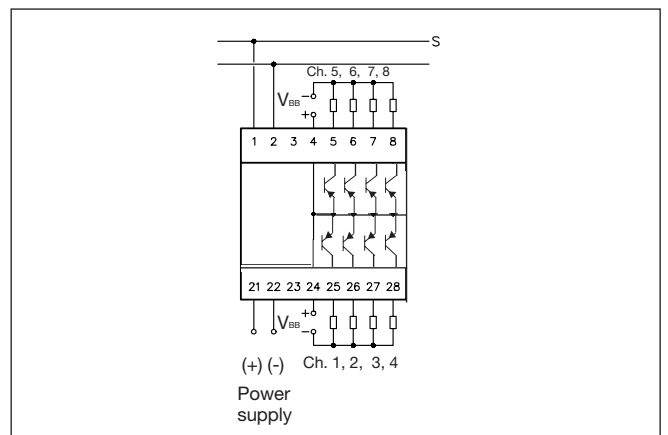

Dimensions (mm)

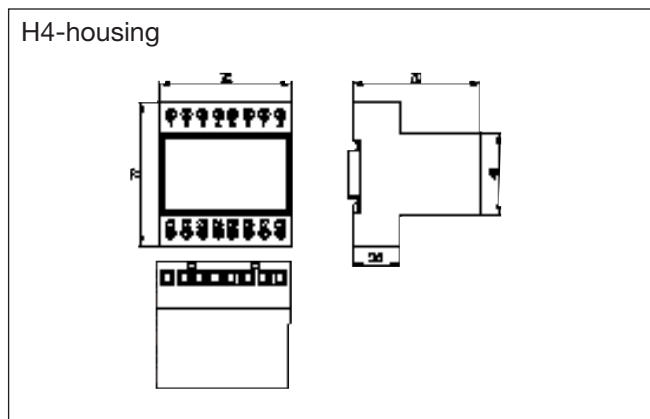

S: Signal wire

Accessories

DIN-rail FMD 411

For further information, see "Accessories".